



CORDLESS TOOLS

Industrial



SUMAKE COMPANY PROFILE

Sumake is a manufacturer and exporter specializing in professional high quality pneumatic tools, compressors and accessories suited to a wide range of applications including industrial and automotive.

We are an innovative company.

As a result of constant research and investment we keep at the forefront of current technology and design, thus providing energy efficient, durable and reliable products to industrial markets around the world.

We offer a wide, comprehensive range of CE certified tools and accessories including: Brushless Electric Screwdrivers, Transducerized DC Tools, Torque Readout and Screw Counting System, just to name a few.

Certified to ISO 9001 we run efficient well organized computerised Q.C. ensure we meet quality, packaging and delivery benchmarks.

We guarantee our customers complete spare parts back up for everything we provide.

Superior service to our customers is not a goal, it's a reality.

Sumake, partners in business.



SUMAKE has attended many international exhibitions and is known for a variety of high-end innovations with vivid posters. Our outstanding showcase is not only eye-catching but also provides hands-on experience for visitors.

INDEX

PISTOL TYPE



10.8V FULL AUTO SHUT-OFF CORDLESS SCREWDRIVER P1

STRAIGHT TYPE



7.2V & 10.8V FULL AUTO SHUT-OFF CORDLESS SCREWDRIVER P2 ~ 3

SHUT-OFF



18V FULL AUTO SHUT-OFF CORDLESS ANGLE WRENCH P4 ~ 5

SHUT-OFF & SEMI AUTO



18V BRUSHLESS FULL AUTO SHUT-OFF & SEMI-AUTO SCREWDRIVER P6 ~ 7

MECHANICAL PULSE



14.4V REMOTE CONTROL TYPE SCREWDRIVER / WRENCH P8

BATTERY & CHARGER



LITHIUM ION BATTERY & CHARGER P9

10.8V BRUSHLESS FULL AUTO SHUT-OFF CORDLESS SCREWDRIVER

Features :

- **High Accuracy Assurance:** $\pm 3\%$ deviation of torque, assure the best quality.
- **Ideal for limited space or areas** where cables and hoses impede handing flexibility e.g., car interior electrical, car assembly, factory assembly etc.
- **High mobility and lightweight ergonomic design:** easy to carry and operate.
- **Dormancy Mode:** Once the screwdriver idles for over 5 seconds, it will turn to sleep mode to save the energy and increase the standby time. The power will be cut off when idle time exceeds 24 seconds, press the trigger to restore power.

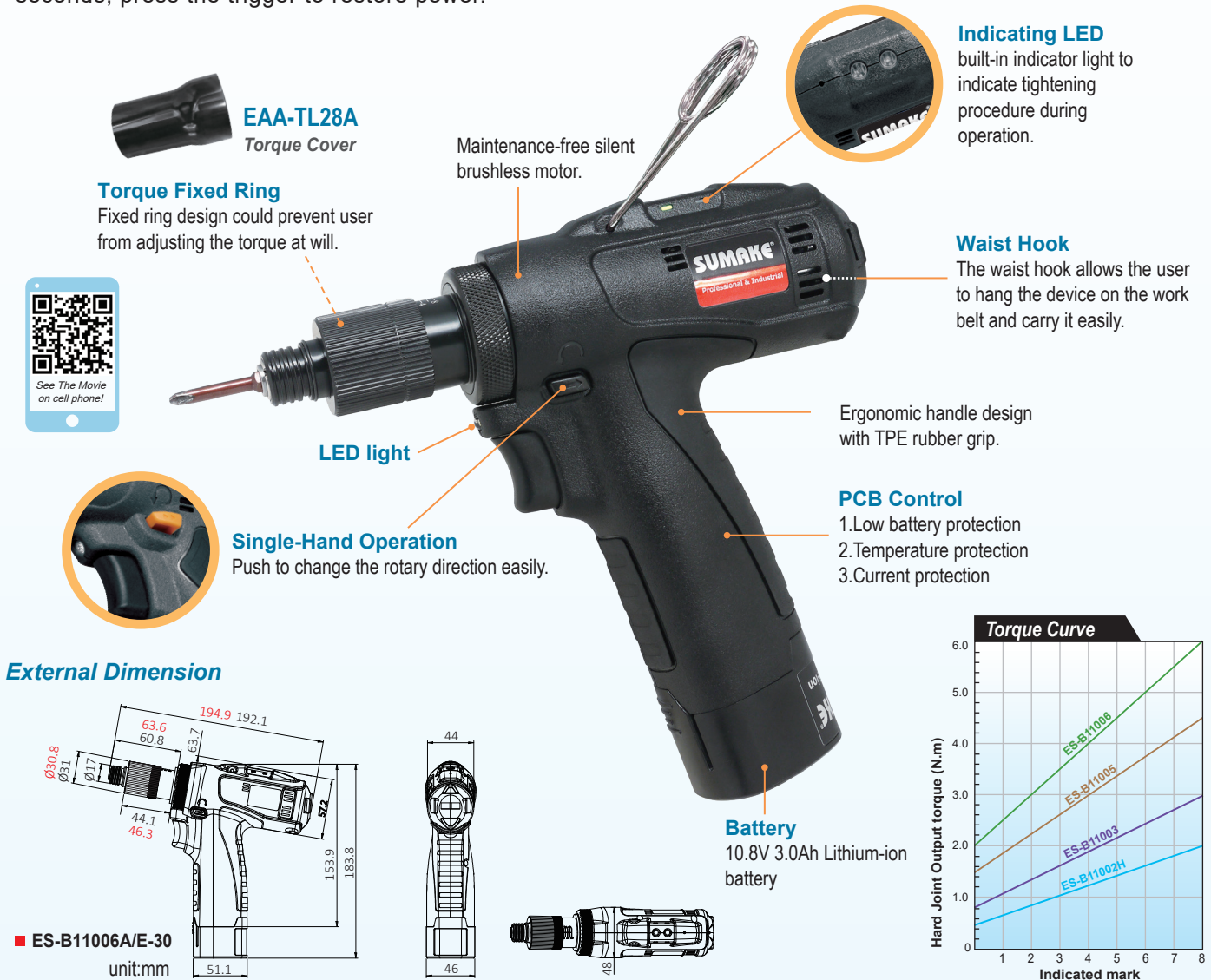

External Dimension

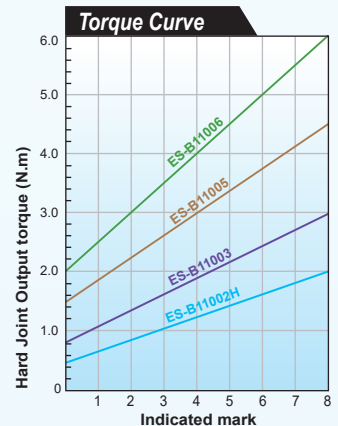
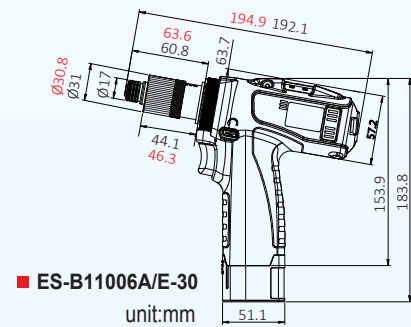

Model No.	Voltage (V)	Free Speed (r.p.m)		Torque Range ($\pm 3\%$)			Weight (w/o Battery)		Dimension L x H (mm) (w/o Battery)	Battery Pack	Bit Type
		High	Low	ft-lbs (Hard Joint / Soft Joint)	N.m (Hard Joint / Soft Joint)	kgf/cm (Hard Joint / Soft Joint)	kg	lbs			
ES-B11002HA/E-30	10.8	2700	1900	0.37 - 1.48 0.37 - 1.18	0.5 - 2.0 0.5 - 1.6	5 - 20 5 - 16	0.7	1.54	189 x 157	BP1030L x 2 pcs	
ES-B11003A/E-30	10.8	1400	1000	0.59 - 2.21 0.59 - 1.77	0.8 - 3.0 0.8 - 2.4	8 - 30 8 - 24	0.7	1.54	189 x 157	BP1030L x 2 pcs	A,B
ES-B11005A/E-30	10.8	800	550	1.11 - 3.32 1.11 - 2.66	1.5 - 4.5 1.5 - 3.6	15 - 45 15 - 36	0.7	1.54	189 x 157	BP1030L x 2 pcs	
ES-B11006A/E-30	10.8	650	450	1.48 - 4.42 1.48 - 3.54	2.0 - 6.0 2.0 - 4.8	20 - 60 20 - 48	0.7	1.54	189 x 157	BP1030L x 2 pcs	B

*Standard tool with ESD housing & 2 batteries.

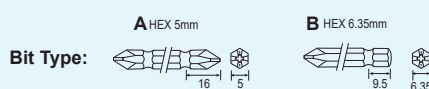

7.2V BRUSHLESS FULL AUTO SHUT-OFF CORDLESS SCREWDRIVER

Features :

- **High Accuracy Assurance:** $\pm 3\%$ deviation of torque, assure the best quality.
- **Ideal for limited space or areas** where cables and hoses impede handing flexibility.
- **High mobility and lightweight ergonomic design,** easy to carry and operate.
- **Dormancy Mode:** Once the screwdriver idles for over 5 seconds, it will turn to sleep mode to save the energy and increase the standby time. The power will be cut off when idle time exceeds 24 seconds, press the trigger to restore power.

Waist Hook

It is convenient for the production lines efficiently to have spring balancers to work together with the tools to be more.



PCB Control

1. Low battery protection
2. Temperature protection
3. Current protection

7.2V 3.0Ah Lithium-ion Battery

Torque Adjustment Ring

Turn torque adjust ring counter clockwise to increase torque output.

Forward / Reverse

Indicating LED

(OK/NG/Power/Hi&Lo)
built-in indicating light to indicate faster procedure during operation.

Brushless Motor

Ergonomic design

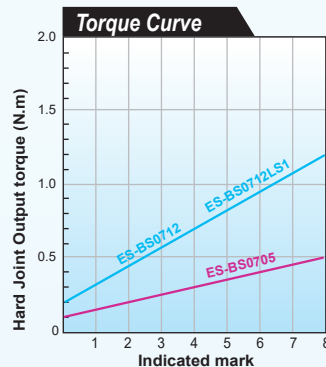
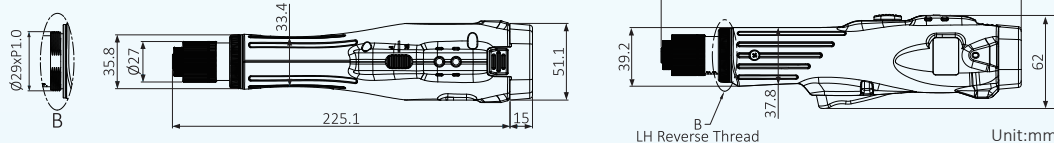

Model No.	Voltage (V)	Free Speed (r.p.m)		Torque Range($\pm 3\%$)			Weight (w/o Battery)		Dimension L x W (mm) (w/o Battery)	Battery Pack	Bit Type
		High	Low	ft-lbs (Hard Joint) (Soft Joint)	N.m (Hard Joint) (Soft Joint)	kgf/cm (Hard Joint) (Soft Joint)	lbs	kg			
ES-BS0705A/E-30	7.2V	1000	700	0.07 - 0.37 0.07 - 0.3	0.1 - 0.5 0.1 - 0.4	1 - 5 1 - 4	1.17	0.53	225 x 62	BP0730L x 2 pcs	
ES-BS0712A/E-30	7.2V	1000	700	0.15 - 0.89 0.15 - 0.71	0.2 - 1.2 0.2 - 0.96	2 - 12.2 2 - 9.8	1.17	0.53	225 x 62	BP0730L x 2 pcs	B
ES-BS0712LS1A/E-30	7.2V	500	350	0.15 - 0.89 0.15 - 0.71	0.2 - 1.2 0.2 - 0.96	2 - 12.2 2 - 9.8	1.17	0.53	225 x 62	BP0730L x 2 pcs	

*Standard tool with ESD housing & 2 batteries.

B HEX 6.35mm

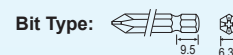

10.8V BRUSHLESS FULL AUTO SHUT-OFF CORDLESS SCREWDRIVER

Features :

- **High Accuracy Assurance:** 3% deviation of torque (Shut off type), assure the best quality.
- **Economy:** Wide-ranging torque with longer life cycle of motor (2 years Motor guarantee for shut off type).
- **Dormancy Mode (Power saving):** Once the screwdriver idles for over 3 second, it will turn to dormancy mode to save the energy and increase the standby time.

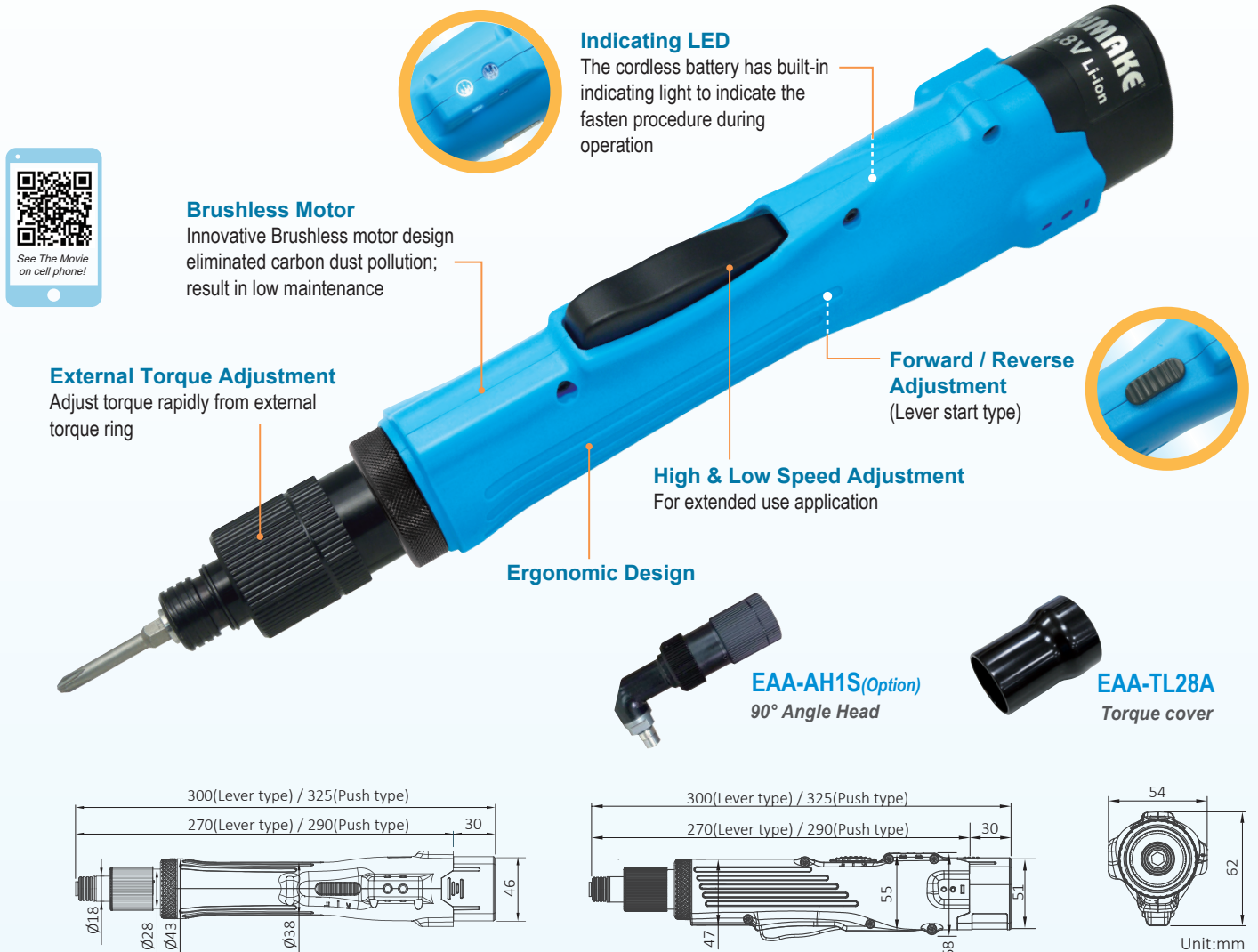

Model No.	Voltage (V)	Free Speed (r.p.m)		Torque Range(±3%) (Hard Joint) (Soft Joint)			Weight (w/o battery)		Dimension (mm) w/o Battery	Battery Pack	Bit Type
		High	Low	ft-lbs	N.m	kgf/cm	kg	lbs			
Lever Start Type											
ES-BS1002A-30	10.8	1200	850	0.22 - 1.48 0.22 - 1.18	0.3 - 2.0 0.3 - 1.6	3.1 - 20.4 3.1 - 16.3	0.67	1.48	270 x 62	BP1030L x 2 pcs	A,B
ES-BS1003A-30	10.8	1200	850	0.59 - 2.22 0.59 - 1.8	0.8 - 3.0 0.8 - 2.4	8.2 - 30.6 8.2 - 24.5	0.67	1.48	270 x 62		
ES-BS1004A-30	10.8	700	500	1.11 - 3.33 1.11 - 2.66	1.5 - 4.5 1.5 - 3.6	15.3 - 45.9 15.3 - 36.7	0.67	1.48	270 x 62		
Push To Start Type											
ES-BS1002PA-30	10.8	1200	-	0.37 - 1.48 0.37 - 1.18	0.5 - 2.0 0.5 - 1.6	5.1 - 20.4 5.1 - 16.3	0.69	1.52	290 x 62	BP1030L x 2 pcs	B
ES-BS1003PA-30	10.8	1200	-	0.7 - 2.2 0.7 - 1.78	1.0 - 3.0 1.0 - 2.4	10.2 - 30.6 10.2 - 24.5	0.69	1.52	290 x 62		
ES-BS1004PA-30	10.8	700	-	1.5 - 3.32 1.5 - 2.66	2.0 - 4.5 2.0 - 3.6	20.4 - 45.9 20.4 - 36.7	0.69	1.52	290 x 62		

*Standard tool with 2 batteries.
*Optional: ESD housing available.

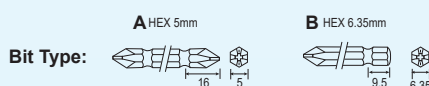

18V BRUSHLESS FULL AUTO SHUT-OFF CORDLESS ANGLE SCREWDRIVER & WRENCH



18V BRUSHLESS FULL AUTO SHUT-OFF CORDLESS ANGLE SCREWDRIVER & WRENCH

Protection & safety:

- Over electric current protection.
- Slow rotation protection.
- Reverse control protection.
- Battery Self-identified & Sleep mode
- (Energy saved).

- Low power protection.
- Thermal protection.
- Stall protection.



Charger

- Identification Of Original Battery Device: identify whether the battery is original or not, if not, the battery can not be charged. (BC21L03)



BC21L02
Weight : 0.53kg
BC21L03
Weight : 0.55kg
21 Voltage Charger



BC21L04
21 Voltage Charger
Weight : 0.53kg

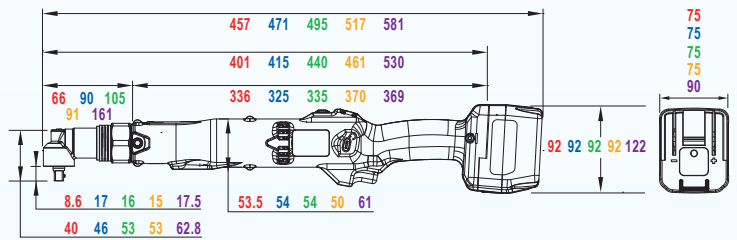

■ Body I ■ Body II ■ Body III ■ Body IV ■ Body V

Unit: mm

Model No.	Voltage (V)	Free Speed (r.p.m) High Low	Torque Range (Accuracy±5%)			Weight (w/o Battery)		Dimension (WxLxH) (mm)	Battery Pack	Option Charger	Bit Type	
			in-lbs (Hard Joint / Soft Joint)	Nm (Hard Joint / Soft Joint)	Kgf/cm (Hard Joint / Soft Joint)	lbs	kg				Standard	Option
Body I												
EAS-B1805H-30	18	1,200 800	17.7~44.3 17.7~35.4	2~5 2~4	20~50 20~40	2.76	1.25	75x457x92	BP1832L	BC21L04	B	-
EAS-B1807-30	18	850 550	22.1~62.0 22.1~49.6	2.5~7 2.5~5.6	25~70 25~56	2.76	1.25	75x457x92	BP1832L			
Body II												
EAS-B1812-30	18	550 350	53.1~106.2 53.1~85	6~12 6~9.6	60~120 60~96	3.31	1.5	75x471x92	BP1832L	BC21L04	B	W Square Drive 3/8"
Body III												
EAS-B1815-30	18	350 220	70.8~132.8 70.8~106.2	8~15 8~12	80~150 80~120	4.08	1.85	75x495x92	BP1832L			
Body IV												
EAS-B1808H-30	18	1200 800	26.6~70.8 26.6~56.6	3~8 3~6.4	30~80 30~64	4.19	1.9	75x517x92	BP1832L	BC21L04	B	W Square Drive 3/8"
EAS-B1815H-30	18	850 550	70.8~132.8 70.8~106.2	8~15 8~12	80~150 80~120	4.19	1.9	75x517x92	BP1832L			
EAW-B1830-30	18	350 220	106.2~265.5 106.2~212.4	12~30 12~24	120~300 120~240	4.19	1.9	75x517x92	BP1832L	BC21L04	W Square Drive 3/8"	-
Body V												
EAW-B1845-40	18	200 130	132.8~398.3 132.8~318.6	15~45 15~36	150~450 150~360	6.27	2.85	90x581x122	BP1841L	BC21L02 BC21L03	W Square Drive 1/2"	-
EAW-B1860-40	18	200 130	221.3~531 221.3~424.8	25~60 25~48	250~600 250~480	6.27	2.85	90x581x122	BP1841L			

*Free load speed will be fixed when battery volume is more than 17V (17~21V).

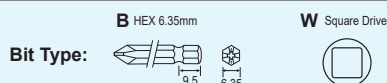

18V BRUSHLESS FULL AUTO SHUT-OFF CORDLESS SCREWDRIVER

Features :

- **High Accuracy Assurance:** 3% deviation of torque (Shut off type), assure the best quality.
- **Economy:** Wide-ranging torque with longer life cycle of motor (2 years Motor guarantee for shut off type).
- **Less Counterforce:** Special mechanical structure and motor improve the safety of operator and reduce occupational disease.
- **Energy Saving:** With efficiency motor provide 8000 screws on loading 6Nm torque – ES-B1806-30 with fully charged battery.
- **Dormancy Mode (Power saving):** Once the screwdriver is idle for over 3 seconds, it will enter sleep mode to save energy and increase standby time.



Torque Fixed Ring

Fixed ring design could prevent user from adjust the torque at will.
 *For Small body I model no. EAA-TC16A
 *For Small body II model no. EAA-TC17A



High & Low Speed Adjustment

For extended use application



OK/NG Indication

The LED green flash – one short buzz means “OK - Shut Off “

The LED red flash – one long buzz means “NG”

Low Cell Warning

20%: Flash red Light - pls change battery;
 10%: Red light - power cut off



External Torque Adjustment

Adjust torque rapidly from external torque ring

LED light

Single-Hand Operation

Push to change the rotary direction easily.

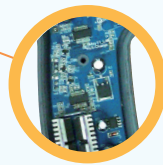

PCB Control

- MOS temperature protection
- Anti-rotating protection

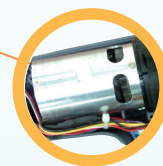

Brushless Motor

Innovative brushless motor design eliminated carbon dust pollution; result in low maintenance

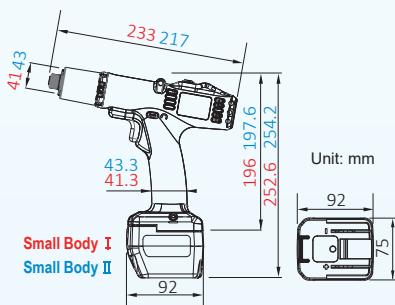

With efficient motor increase the productivity.

★ The performance of ES-B1806-30 with full charged battery can reach to 8,000 screws on loading 6Nm torque.

Model No.	Voltage (V)	Free Speed (r.p.m)		Torque Range (±3%)			Weight (w/o battery)		Dimension (WxLxH) (mm)	Battery Pack	Bit Type	
		High	Low	ft-lbs (Hard Joint / Soft Joint)	Nm (Hard Joint / Soft Joint)	Kgf/cm (Hard Joint / Soft Joint)	kg	lbs				
Small Body I	18	ES-B1803-30	1,000	650	0.7-2.6 / 0.7-2.1	1.0-3.5 / 1.0-2.8	10.2-35.7 / 10.2-28.6	1.02	2.25	75x217x252	BP1832L	B,F
		ES-B1803H-30	2,000	1,300	0.7-2.6 / 0.7-2.1	1.0-3.5 / 1.0-2.8	10.2-35.7 / 10.2-28.6	1.02	2.25	75x217x252		
		ES-B1806-30	1,000	650	1.5-4.4 / 1.5-3.6	2.0-6.0 / 2.0-4.8	20.4-61.2 / 20.4-48.9	1.02	2.25	75x217x252		
Small Body II	18	ES-B1805H-30	2,200	1,400	1.5-3.7 / 1.5-3.0	2.0-5.0 / 2.0-4.0	20.4-51.0 / 20.4-40.8	1.16	2.56	75x233x254		
		ES-B1809-30	1,000	650	2.2-6.7 / 2.2-5.3	3.0-9.0 / 3.0-7.2	30.6-91.8 / 30.6-73.4	1.16	2.56	75x233x254		
		ES-B1812-30	880	570	4.4-8.9 / 4.4-7.1	6.0-12.0 / 6.0-9.6	61.2-122.4 / 61.2-97.9	1.16	2.56	75x233x254		

Model No. with "A" includes 2 batteries. e.g.ES-B1803A-20





18V BRUSHLESS FULL AUTO SHUT-OFF & SEMI-AUTO CORDLESS SCREWDRIVER

2 years

Brushless Motor
GUARANTEE



Wrench
Internal torque adjustment

Auto Shut-off

ES-B1808L-20

ES-B1812L-20

2.0Ah Li-ion battery

ES-B1808L-40

ES-B1812L-40

ES-B1815L-40

ES-B1822L-40

4.0Ah Li-ion battery
(Long-Lasting Type)



Powerful Torque



Torque Rings

SUMAKE Color Rings give you an easily visible torque marking system at a glance. Choose the color for each torque level used on your assembly line

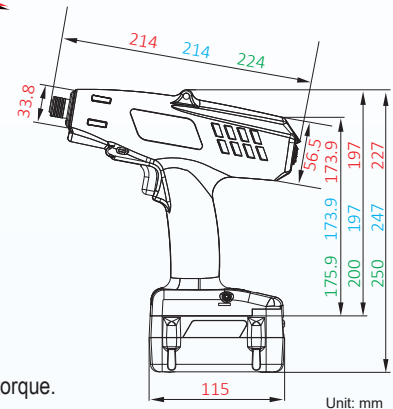

★ **With efficient motor increase the productivity.**

The performance of ES-B1822L-40 with full charged battery can reach to 6,000 screws on loading 22Nm torque.

1 years

Brushless Motor
GUARANTEE



External Torque Adjustment
Adjust the torque rapidly

Semi-Auto

ESS-B1805-20

ESS-B1808-20

ESS-B1812-20

2.0Ah Li-ion battery

ESS-B1805-40

ESS-B1808-40

ESS-B1812-40

4.0Ah Li-ion battery
(Long-Lasting Type)

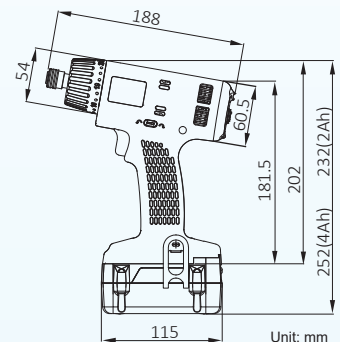

Model No.	Voltage (V)	Free Speed (r.p.m)			Torque Range (±10%)			Weight (w/Battery)		Dimension (WxLxH) (mm)	Battery Pack	Bit Type
		High	Mid	Low	ft-lbs (Hard Joint) (Soft Joint)	Nm (Hard Joint) (Soft Joint)	Kgf/cm (Hard Joint) (Soft Joint)	lbs	kg			
Full Auto Shut-Off Type												
ES-B1808L-20	18	1,200	-	780	3.0-5.9	4.0-8.0	40.8-81.6	2.97	1.35	90x214x227	BP1821L	B,F
ES-B1808L-40					3.0-4.7	4.0-6.4	40.8-65.3					
ES-B1812L-20	18	720	-	450	3.7~8.9	5.0-12.0	51.0-122.4	2.97	1.35	90x214x227	BP1821L	
ES-B1812L-40					3.7~7.1	5.0-9.6	51.0-97.9					
ES-B1815L-40	18	600	-	380	4.4-11.0 4.4-8.9	6.0-15.0 6.0-12.0	61.2-153 61.2-122.4	3.6	1.65	90x224x250	BP1841L	B,F,W
ES-B1822L-40	18	350	-	200	5.9-16.3 5.9-13.0	8.0-22.0 8.0-17.6	81.6-224.3 81.6-179.5	4.2	1.9	90x224x250	BP1841L	
Semi-Auto Type												
ESS-B1805-20	18	2,200	1,600	1,100	1.1-3.7	1.5-5.0	15.3-51.0	2.97	1.35	90x188x232	BP1821L	B,F,W
ESS-B1805-40					1.1-3.0	1.5-4.0	15.0-40.8					
ESS-B1808-20	18	1,200	900	600	3.0-5.9	4.0-8.0	40.8-81.6	2.97	1.35	90x188x232	BP1821L	
ESS-B1808-40					3.0-4.7	4.0-6.4	40.8-65.3					
ESS-B1812-20	18	700	500	350	4.4-8.9	6.0-12.0	61.2-122.4	2.97	1.35	90x188x232	BP1821L	
ESS-B1812-40					4.4-7.1	6.0-9.6	61.2-97.9					

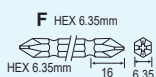
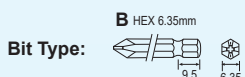

Model No. with "A" includes 2 batteries. e.g.ES-B1808LA-20

BRUSHLESS CORDLESS MECHANICAL PULSE SCREWDRIVER (Remote Control Type)

Applications

Ideal tool for precise torque and assembling process management in production line.

Precise-machined mechanical pulse mechanism.

Durable brushless motor

Built-in LED light

Ergonomic handle design with soft rubber grip

Programed data display panel

Built-in control processing unit

OK/NG Indicator for error warning: Capable to detect the NG situation such as wrong screw size, screw stripped and screw breaks.

OK in green light **NG in red light** **OKALL (program/job complete) in orange light**

Job select **Program(P):** 1~5 jobs
Batch Count(N): 1~99 screw/nut counts
Force(F): 1-3 power selection for EMW-14100(F)-30, EMW-14200F-30
Impacts(H): 1~99 pulse steps for EMS(W)-B1470-30, EMW-14100(F)-30
Limit(L): 1~50 pulse steps for EMS(W)-B1450-30
 1~99 screw/nut rotations

Buzz on/off **Display panel lock/unlock** **Setting data save**

Tool's program only can be set by remote controller
 After 3 min stand by, tool will be switched off automatically.

SRC-01 Remote control
Remote controller function layout for program/torque setting:
 5 unique job model setting with the combination of 6 power output selection multiplied by 99 pulse steps.

14.4V Li-ion 3.0Ah / 36Wh
 SUMAKE Industrial Co., Ltd.

See The Movie on cell phone!

Model No.	Bit Type	Voltage (V)	Free Speed (r.p.m)	Blow Per Minute (b.p.m)	Max Torque (HoF mode)	Torque Range			Bolt Capacity	Overall Length (LxH) (w/o Battery)		Net Weight (w/ Battery)		Battery Pack	Battery Charger
						Nm	lbf-in	Nm		Kgf/cm	mm	in	kgs		
EMS-B1450-30	Hex 6.35 mm	14.4	1,900	2,500	70	35.4~309.8	4-35	40.8~356.9	M6~M8	175 x 196	6.89 x 7.72	1.31	2.89	BP1430L	BC16L01
EMW-B1450-30	3/8" Square														
EMW-B14100-30	3/8" Square	14.4	2,000	2,600	90	88~396	10-45	102~458.9	M8 ~M10	175 x 196	6.89 x 7.72	1.35	2.98	BP1430L	BC16L01
EMW-B14100F-30	1/2" Square														
EMW-B14200F-30	1/2" Square	14.4	1,700	2,100	170	105.6~792	12-90	122.4~917.7	M8~M12	219 x 220	8.62 x 8.66	1.83	4.03	BP1430L	BC16L01

BATTERY & CHARGER (Lithium Ion)

Lithium Ion Battery

- High performance Li-ion battery.
- Built in protection device to prevent battery overcharge and over discharge.
- The latch design increases intensity and convenience.
- Over-temperature protection (discharge): 72°C



BP0730L
7.2V 3.0Ah(42.5Wh)
Weight : 0.12kg



BP1030L
10.8V 3.0Ah(42.5Wh)
Weight : 0.18kg



BP1430L
14.4V 3.0Ah (42.5Wh)
Weight : 0.33kg



BP1832L
18V 3.0Ah(36Wh)
Weight : 0.49kg



BP1821L
18V 2.0Ah(36Wh)
Weight : 0.43kg



BP1841L
(Long-Lasting type)
18V 4.0Ah(70Wh)
Weight : 0.72kg

Charger



BC08L01
8.4V



BC10L01
12.6V



BC16L01
16.8V



BC21L02
BC21L03
21V



BC21L04
21V

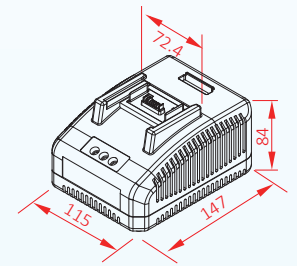
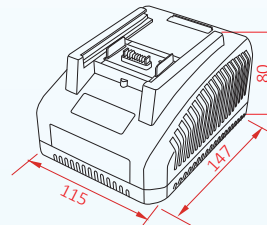
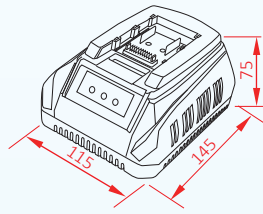
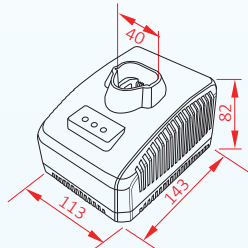
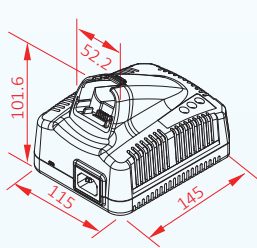

Unit: mm

	BC08L01	BC10L01 / BC16L01	BC21L02 / BC21L03 / BC21L04
	Power on(Identification of Original Battery)	1 shut buzz	1 shut buzz
	Charging	x	x
	Charging > 80%	x	x
	Fully Charged	3 long buzz	3 long buzz
	Incorrect Battery Type or Battery NG	shut buzz continuously	shut buzz continuously

Charger Comparison Sheet

Model No.	Input Voltage	Output Voltage	Output Current	Charging Time	LCD	Identification Of Original Battery	Warning (Buzz)	Weight (Kg)	Types of Battery	Features
BC08L01	100-240V	8.4V	3A	Abt. 40mins	x	●	●	0.43		<ul style="list-style-type: none"> • SUMAKE battery chargers are compact size, light weight, quick recharge and wide voltage range 90~240V can be applicable worldwide. • Battery temperature detector and protection. • ID identification only allows the SUMAKE charger to charge to ensure battery safety and extend battery life.
BC10L01	100-240V	12.6V	3A	Abt. 40mins	x	●	●	0.47		
BC16L01	100-240V	16.8V	3A	Abt. 40mins	x	●	●	0.46		
BC21L02	100-240V	21V	3A	1.95Ah: Abt. 40mins 3.9Ah: Abt. 80mins	x	x	x	0.53		
BC21L03	100-240V	21V	3A	1.95Ah: Abt. 40mins 3.9Ah: Abt. 80mins	x	●	●	0.55		
BC21L04	100-240V	21V	3A	2.0Ah: Abt. 40mins	x	●	●	0.53		

★ A for UL plug / B for Europe plug / C for UK plug / D for Aus / E for India / F for China / G for Brasil / J for PSE(Japan)



Electric Screwdrivers



Industrial Air Screwdriver



Automatic Screw Feeder



Oil Pulse Tools



Compressors & Air Pump



Air Nailer & Air Stapler



Impact Sockets



Industrial Air Sander



Torque Wrench



SUMAKE®

SUMAKE Industrial Co., Ltd.

4F, NO.351, Yangguang St., Neihu District, Taipei, Taiwan

Tel: 886-2-2659-3500 Fax: 886-2-2659-3700

<http://www.sumake.com> <http://www.aircompressors.com.tw>

E-mail: sales@sumake.com



©SUMAKE We reserve the right to make changes without prior notice.

